

Technical News Bulletin

Steinhausen, May 1999

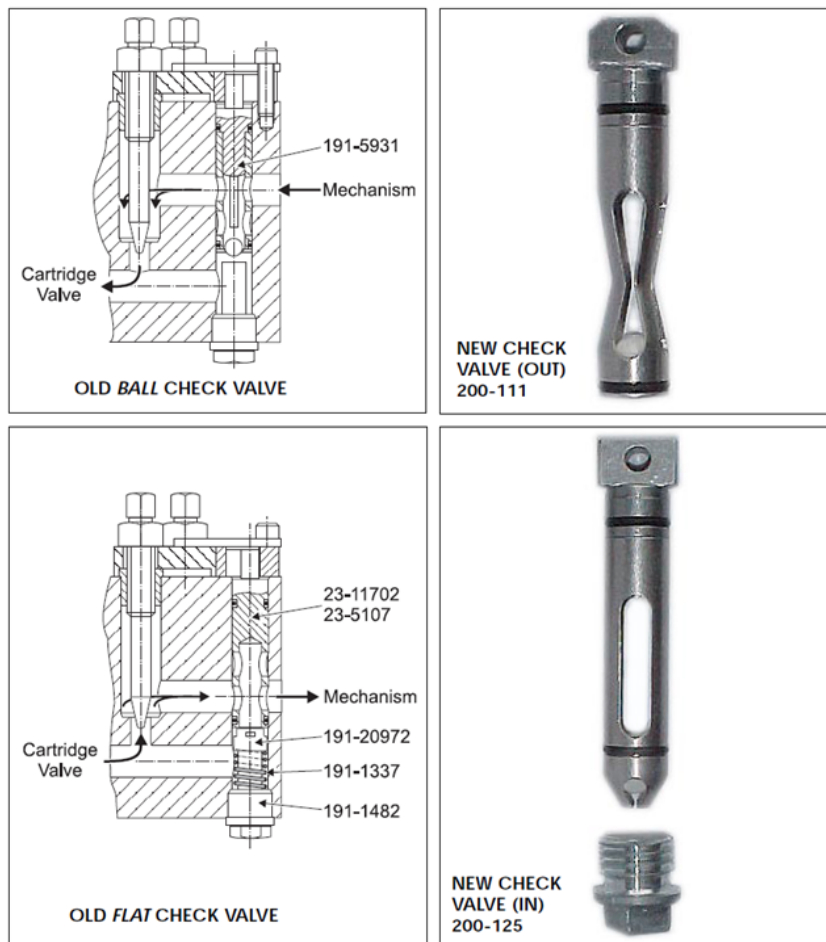

New generation Check Valves for the Electro-Pneumatic Valve Block

- One-piece check valves are equipped with lightweight ceramic ball which results in less impact (wear), and faster response time.
- Easily distinguishable by their different head types.
- Simplified installation, longer lifetime.

Introduction

The new one-piece check valves are equipped with lightweight ceramic ball which results in less impact (wear), faster response time and increased service life.

Description

For enhanced performance a new generation of check valves was designed, which replace the current Ball and Flat check valves. Featuring a high-tech, lightweight ceramic ball instead of the two times heavier steel ball, results in less impact (wear), considerably faster response time and increased service life.

With the unique design of the **check valve (out) 200-111**, which replaces the old type ball check valve, the ceramic ball is kept in a stable position during air flow, preventing any vibration. The **check valve (in) 200-125** which replaces the old type flat check valve, is also equipped with a ceramic ball and uses the same design concept as the well proven check valves in the new Emhart Glass twist mechanisms. The one-piece design simplifies exchangeability from the top of the electropneumatic valve block.

Application Range

The new check valves are applicable on all Electro-pneumatic Valve Blocks (EPVB: 191-7410 resp. 200-255), replacing the previous ball and flat check valves as indicated overleaf and in the ordering information below.

Performance characteristics

Compared to the previous check valves the air throughput of check valve 200-125 is increased by 50% whereas the air throughput of check valve 200-111 is increased by 12%. Air leakage is significantly reduced.

Features / Benefits

- one-piece design
- lightweight, high-tech ceramic ball
- easily distinguishable by their different head types
- simplified installation
- faster dynamic response
- increased air throughput
- longer lifetime

Ordering information and Installation requirements

<table border="1"> <thead> <tr> <th colspan="2"><i>Old ball check valve</i></th> </tr> </thead> <tbody> <tr> <td>Ball check valve</td> <td>191-5931</td> </tr> </tbody> </table>	<i>Old ball check valve</i>		Ball check valve	191-5931	➔	<table border="1"> <thead> <tr> <th colspan="2">New check valve "OUT"</th> </tr> </thead> <tbody> <tr> <td>• Check valve (OUT)</td> <td>200-111</td> </tr> </tbody> </table>	New check valve "OUT"		• Check valve (OUT)	200-111														
<i>Old ball check valve</i>																								
Ball check valve	191-5931																							
New check valve "OUT"																								
• Check valve (OUT)	200-111																							
<table border="1"> <thead> <tr> <th colspan="2"><i>Old flat check valve</i></th> </tr> </thead> <tbody> <tr> <td colspan="2">Flat check valve, consisting of:</td> </tr> <tr> <td>- Plug resp.</td> <td>23-11702</td> </tr> <tr> <td>Plug</td> <td>23-5107</td> </tr> <tr> <td>- Flat check valve</td> <td>191-20972</td> </tr> <tr> <td>- Spring</td> <td>191-1337</td> </tr> <tr> <td>Stud</td> <td>191-1482</td> </tr> </tbody> </table>	<i>Old flat check valve</i>		Flat check valve, consisting of:		- Plug resp.	23-11702	Plug	23-5107	- Flat check valve	191-20972	- Spring	191-1337	Stud	191-1482	➔	<table border="1"> <thead> <tr> <th colspan="2">New check valve "IN"</th> </tr> </thead> <tbody> <tr> <td>Flat check replacement kit</td> <td>200-267</td> </tr> <tr> <td>• Check valve (IN)</td> <td>200-125</td> </tr> <tr> <td>• Stud</td> <td>200-10029</td> </tr> </tbody> </table>	New check valve "IN"		Flat check replacement kit	200-267	• Check valve (IN)	200-125	• Stud	200-10029
<i>Old flat check valve</i>																								
Flat check valve, consisting of:																								
- Plug resp.	23-11702																							
Plug	23-5107																							
- Flat check valve	191-20972																							
- Spring	191-1337																							
Stud	191-1482																							
New check valve "IN"																								
Flat check replacement kit	200-267																							
• Check valve (IN)	200-125																							
• Stud	200-10029																							

Note: Old type studs (191-1482) must be replaced by the **new type studs (200-10029)**, but only in the position where the new check valves (**IN**) are mounted!
The new type studs are shorter to ensure they do not interfere with the bottom of the new check valves!

Availability

The new check valves are available immediately. Electro-pneumatic Valve Blocks 200-255 supplied starting **December 1998** have the new type check valves installed. Instead of the old Ball check valve 191-5931 the new Ball check replacement kit 200-481 (valve 200-111) will be supplied. The old Flat check valves (as listed above) will be available until 2002 as spare parts only!