

## multikon chili-vz / chili-vzs / chili-vzm

### container separation



#### Three optimized systems for different requirements

- multikon chili-vz standard
- multikon chili-vzs compact
- multikon chili-vzm multisort production

#### All systems offer:

- Maximum reliability combined with flexible adjustment options
- Servomotor-driven
- Fully integrated in line control
- Individual adjustments for different types of containers

#### multikon chili-vz and multikon chili-vzm



chili-vz



chili-vzm

#### Function

Separates the containers using two pairs of lateral belts, driven by four servomotors. Incoming containers are gripped securely with the first pair of belts. Shards or downware containers are eliminated through a conveyor gap. The second pair of belts moves by default with a fixed speed ratio of 1:2 to the infeed and thus creates a defined minimal gap between the containers. The speed ratio is variable and can be adjusted flexibly. Lateral belts and conveyor are synchronized when the container is released, no speed difference.

**With vzm:** Containers of different shape and diameter are gripped by foam belts in multi-sort production lines

#### Highlights

- Once separated the containers are released onto the conveyor which runs at the same speed as the belts
- Reliable separation as speed change only inside the belts
- No free standing speed change of the container on the conveyor
- Pressure by incoming containers is absorbed and does not hamper operation
- No line stops due to slipping containers
- Containers cannot fall over
- Servo-drive allows flexible fine adjustment of the belt speeds
- Height adjustment of the belts allows adaption to different container types
- **With vzm:** Separation of containers with up to 30mm diameter difference for multisort production

**scale drawing multikon chili-vz**

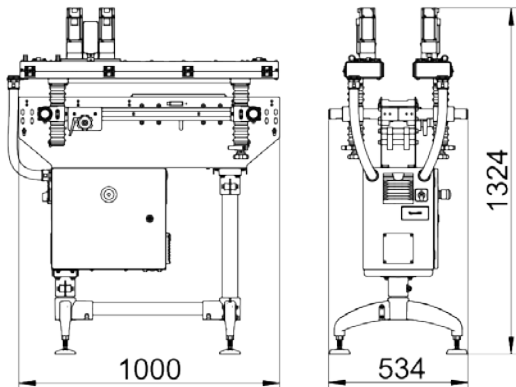

**scale drawing multikon chili-vzm**

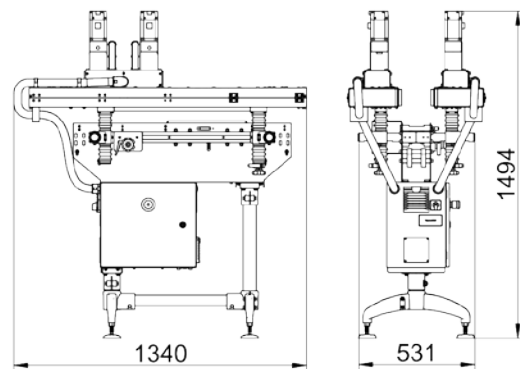

**multikon chili-vzs**

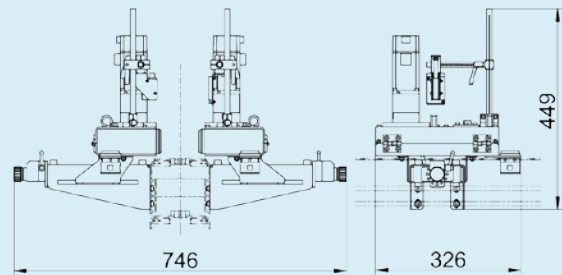
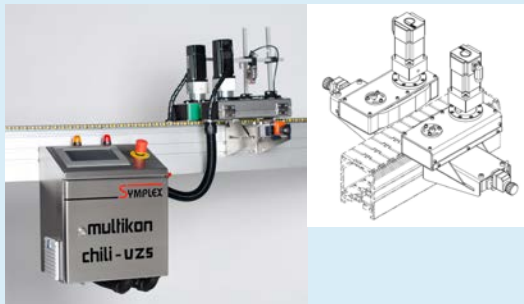

**Function**

Separates the containers using one pair of lateral belts, each driven by a servomotor. Incoming containers are gripped securely in a pair of belts, which generate the optimal separation distance. If the containers are already separated sufficiently, no further separation is applied. The belt speed is flexible and adjusts to the container flow at the infeed assuring optimal container flow and separation.

**Highlights**

- Self-adjusting belt speed minimizes the speed difference on release of the container
- Containers cannot fall over
- No line stops due to slipping containers
- Servo-drive allows flexible fine adjustment of the belt speeds
- Height adjustment of the belts allows adaption to different container types

**Short specification for all separating systems**

- **Performance:** 400 containers / minute, higher speed upon request
- **Conveyor speed:** max. 1 m/s
- **Container dimensions:** Diameter max. 200mm

**Symplex Vision Systems GmbH**

D-80686 München Grüntenstr. 10a Tel. +49 89 552798 0 Fax +49 89 552798 79 info@symplex.de www.symplex.de